

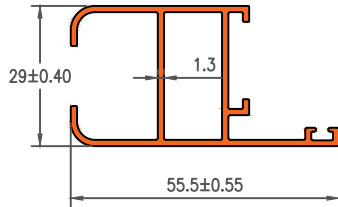

Darshan Extrusions Pvt. Ltd.

Die No.19456

0.594Kg/m



Die No.19457

0.479Kg/m

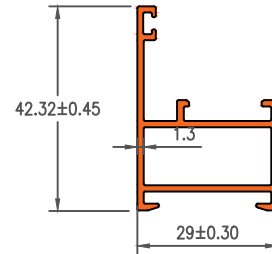

Die No.19727

0.585Kg/m

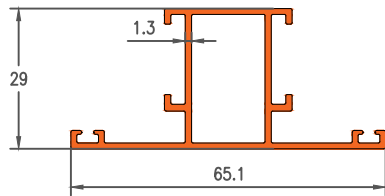

Die No.19728

0.206Kg/m

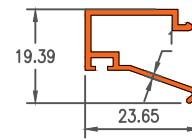

29 MM OPENABLE SERIES



Die No.4001

0.545Kg/m

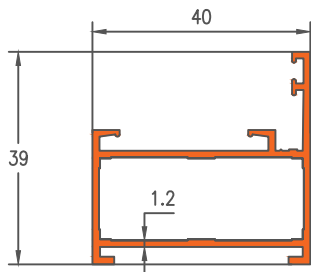

Die No.4002

0.700Kg/m

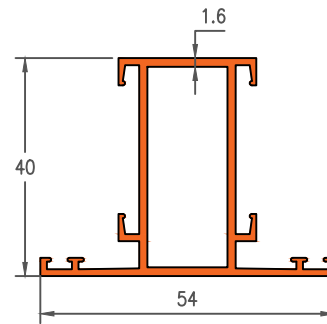

Die No.4003

0.898Kg/m

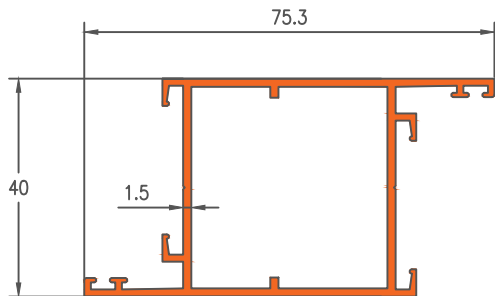

Die No.4004

0.897Kg/m

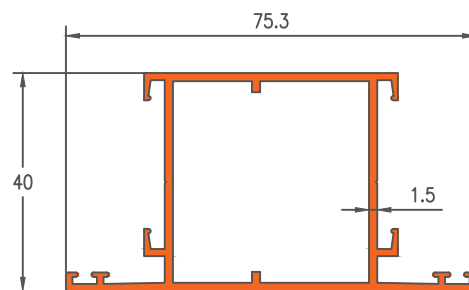

Die No.4005

1.386Kg/m

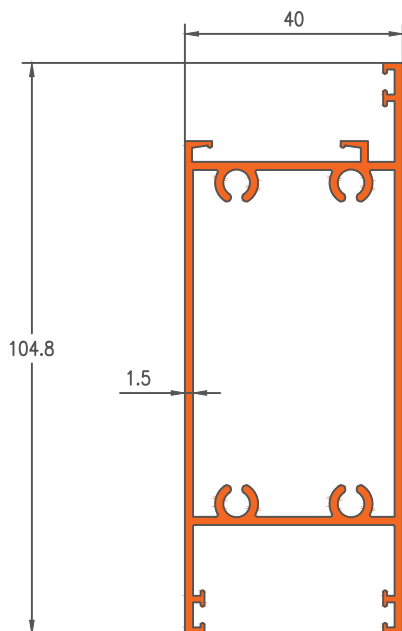

Die No.4006

0.207Kg/m

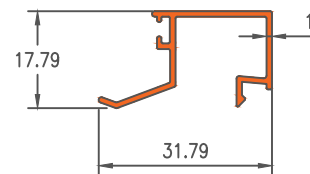

Die No.4007

0.202Kg/m

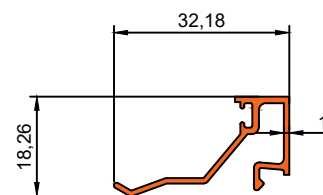



Die No.4008

0.386Kg/m

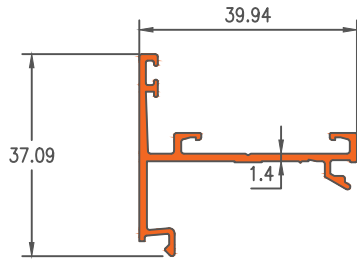

Die No.4009

0.163Kg/m

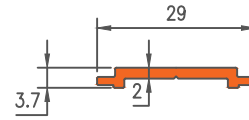

Die No.4010

0.661Kg/m

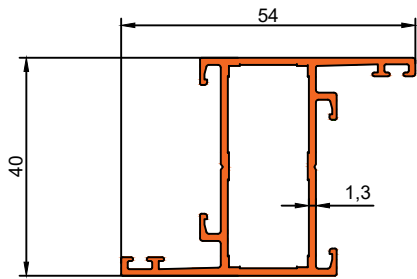

Die No.4011

0.254Kg/m

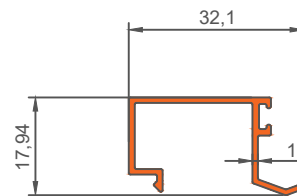

Die No.16048

0.665Kg/m

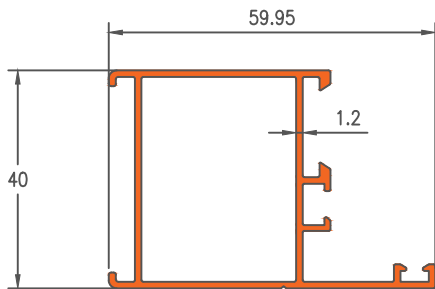

Die No.16047

0.806Kg/m

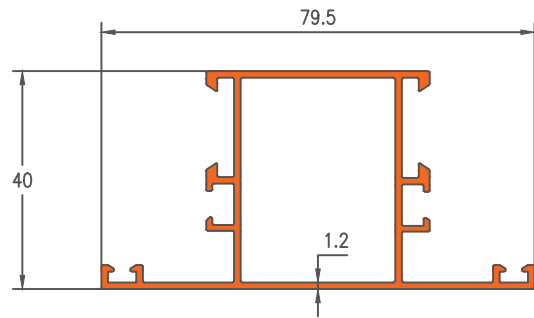

Die No.16055

0.701Kg/m

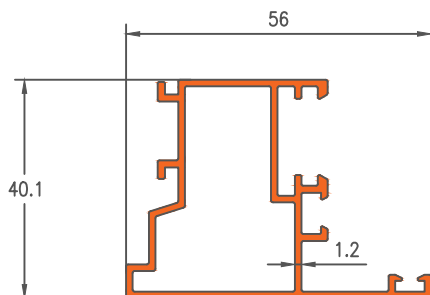



Darshan Extrusions Pvt. Ltd.

Die No.16021

0.716Kg/m

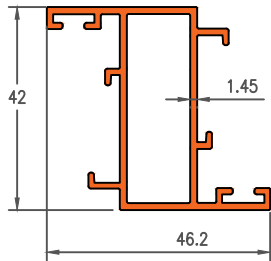

Die No.19458

0.231Kg/m

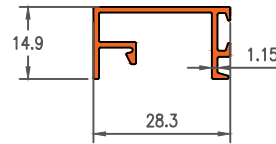

Die No.1383

0.268Kg/m

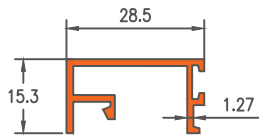

Die No.1382

0.551Kg/m

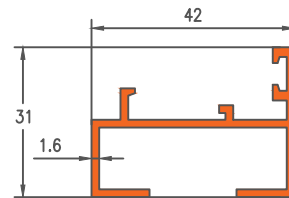

Die No.19713

0.876Kg/m

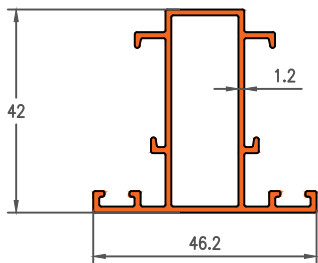

Die No.19717

0.451Kg/m

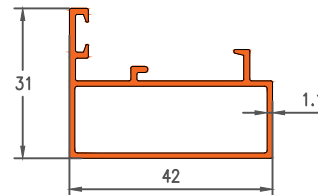

42 MM OPENABLE SERIES



Darshan Extrusions Pvt. Ltd.

Die No. 5103

0.788Kg/m

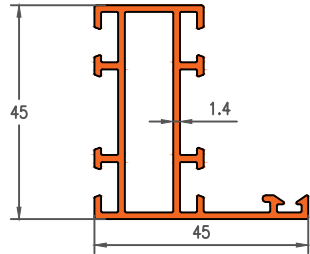

Die No. 5101

0.909Kg/m

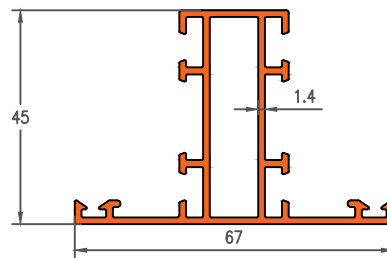

Die No. 5102

0.909Kg/m

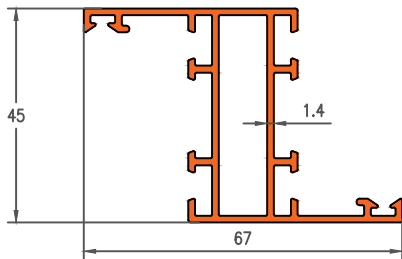

Die No. 5173

0.956Kg/m

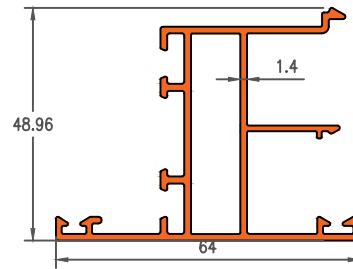

Die No. 5169

0.947Kg/m

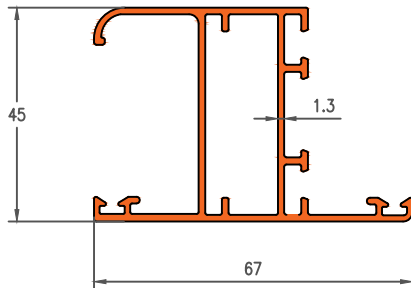

Die No. 5151

1.092Kg/m

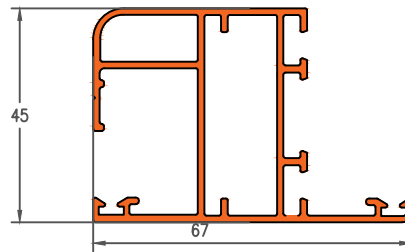

Die No. 5157

0.844Kg/m

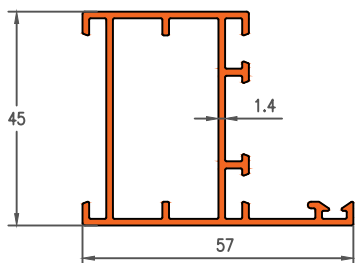

Die No. 5110

0.906Kg/m

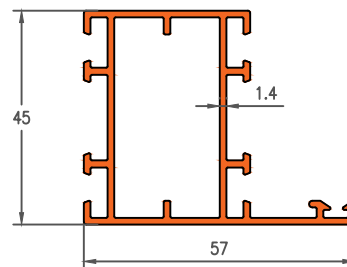

45 MM OPENABLE SERIES



Darshan Extrusions Pvt. Ltd.

Die No. 5109

1.137Kg/m

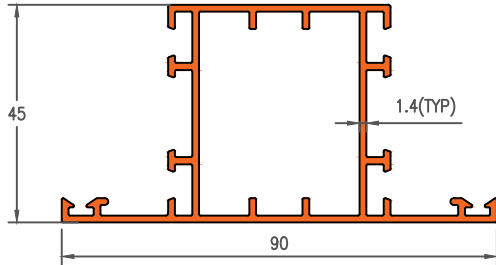

Die No. 5108

1.137Kg/m

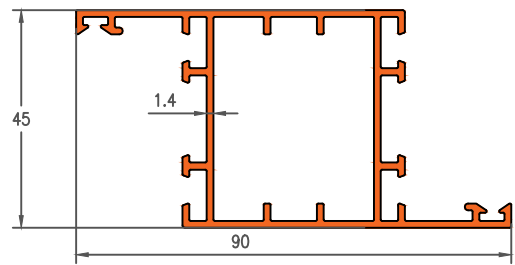

Die No. 5367

0.581Kg/m

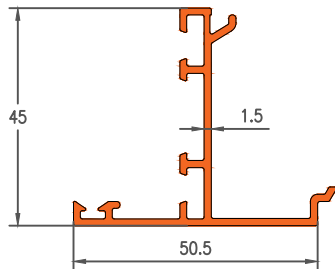

Die No. 5170

0.956Kg/m

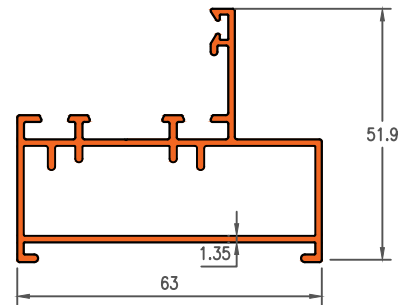

Die No. 5137

1.612Kg/m

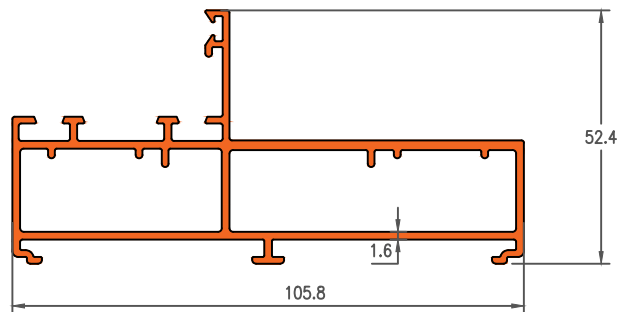

Die No. 3820

1.920Kg/m

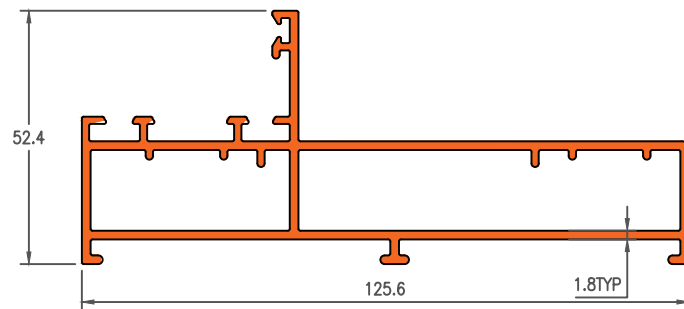

45 MM OPENABLE SERIES



Darshan Extrusions Pvt. Ltd.

Die No.7870

2.283Kg/m

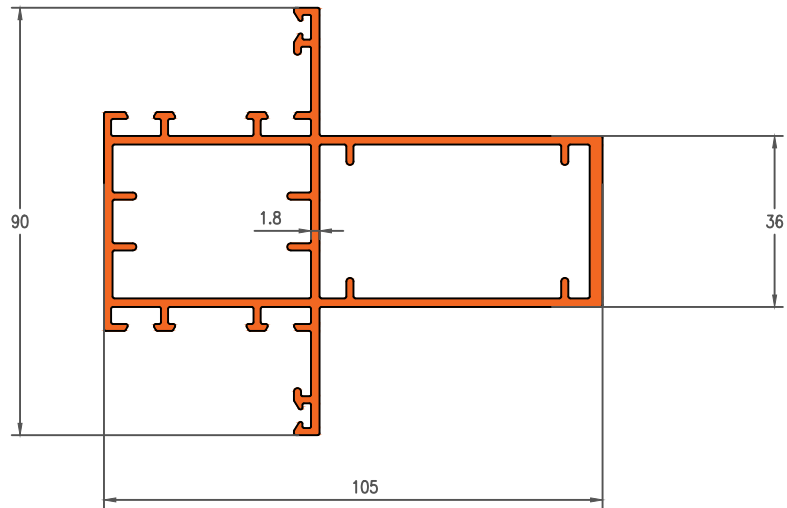

Die No.3819

2.528Kg/m

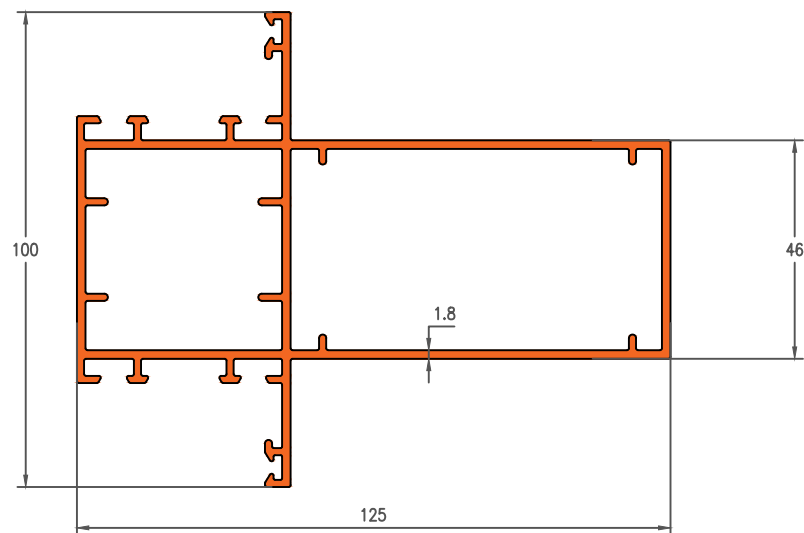

45 MM OPENABLE SERIES



Darshan Extrusions Pvt. Ltd.

Die No.5185

0.279Kg/m

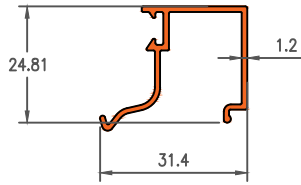

Die No.19643

0.275Kg/m

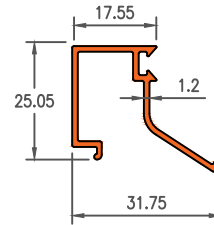

Die No.5150

0.268Kg/m

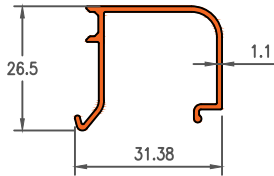

Die No.5149

0.246Kg/m

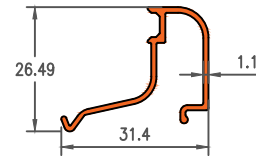

45 MM OPENABLE SERIES



Die No. 5001

0.807Kg/m

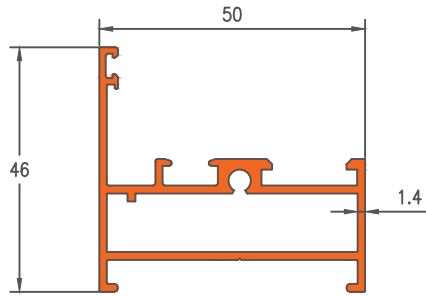

Die No. 5002

0.999Kg/m

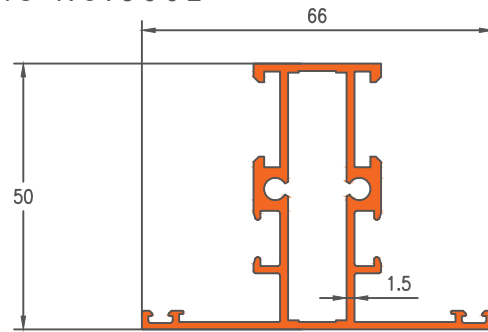

Die No. 5003

1.138Kg/m

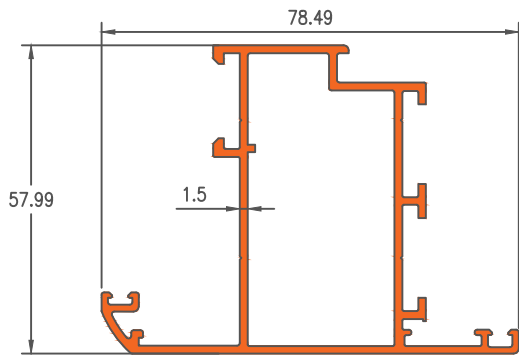

Die No. 5004

0.954Kg/m

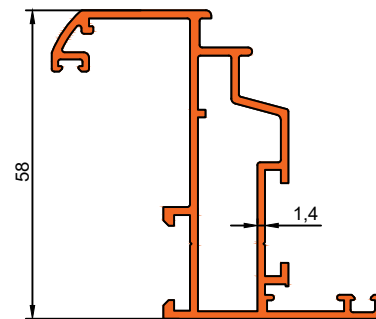

Die No. 5005

1.206Kg/m

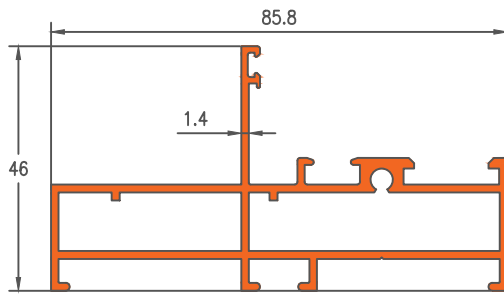

Die No. 5006

0.806Kg/m

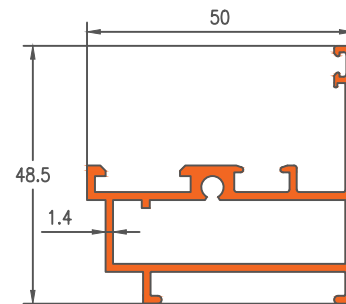

Die No. 5008

1.260Kg/m

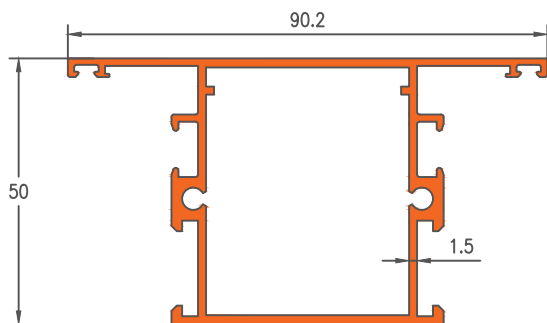



Darshan Extrusions Pvt. Ltd.

Die No. 5009 1.291Kg/m

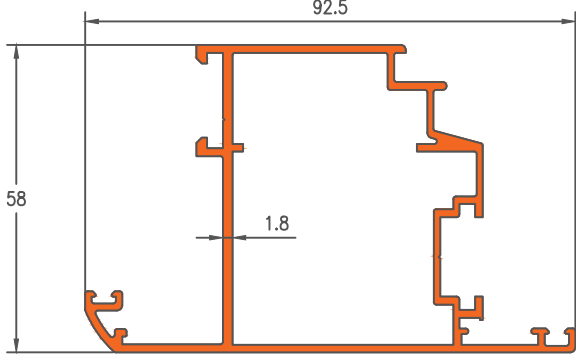

Die No. 5010 0.965Kg/m

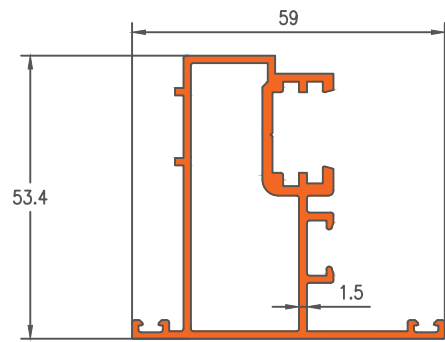

Die No. 5011

2.135 Kg/m

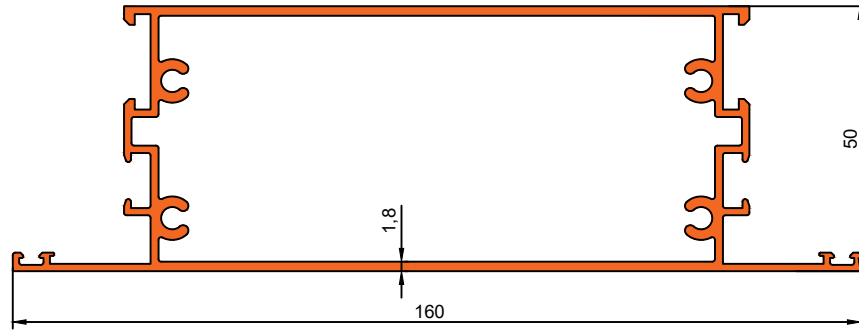

Die No. 5013
0.313Kg/m

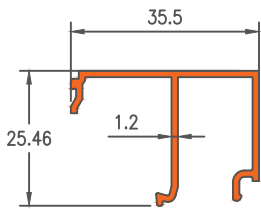

Die No. 5014
0.230Kg/m

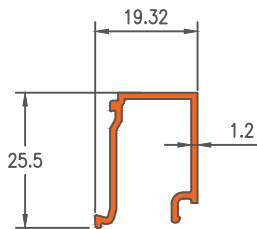

Die No. 5015
0.289Kg/m

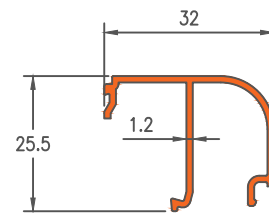

Die No. 5016
0.217Kg/m

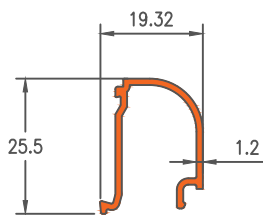

Die No. 5017
0.501Kg/m

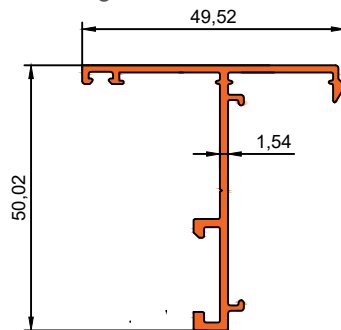

Die No. 5018
0.265Kg/m

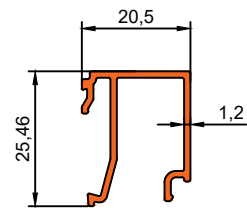

50 MM OPENABLE WINDOW



Darshan Extrusions Pvt. Ltd.

Die No. 19642

1.001Kg/m

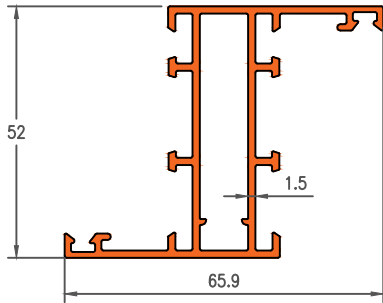

Die No. 19641

0.882Kg/m

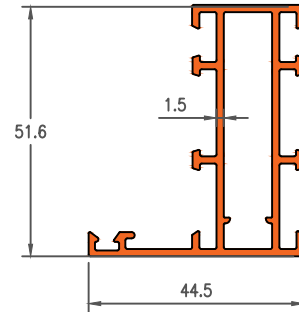

Die No. 19649

0.944Kg/m

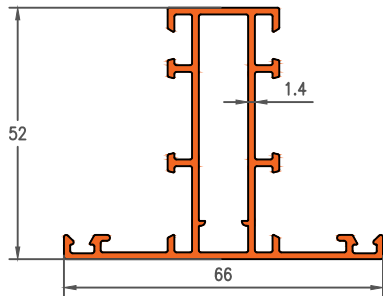

Die No. 19644

0.311Kg/m

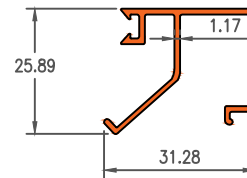

Die No. 19643

0.275Kg/m

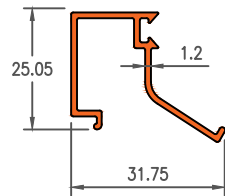

52 MM OPENABLE SERIES